

MOVING TARGET INDICATION RADAR

Abhinav Singh, Vaibhav Shah, Anurag Sarnaik

Thakur College of Engg. and Technology, Thakur Village, Kandivli(E),

Mumbai-400101, India

vaibhav.shah222@gmail.com

Abstract

MTI (Moving Target Indication) radar systems have been built for many years, based on system concepts evolved in the early 1950's. Digital techniques now permit easier implementation, but do not change the basic concepts; staggered repetition periods to eliminate blind speeds; and MTI cancellers with the velocity response shaped by feed forward and feedback techniques. Radar MTI may be specialized in terms of the type of clutter and environment: airborne MTI (AMTI), ground MTI (GMTI), etc., or may be combined mode: stationary and moving target indication (SMTI). The most common approach takes advantage of the Doppler effect. Many of the existing systems are very successful considering their performance, measured in terms of MTI improvement factor or sub clutter visibility. In this paper the basic MTI concepts and definitions are presented, and the real problems of modern surface-based MTI radar systems are discussed.

I. INTRODUCTION

RADAR (Radio Detection and Ranging) is a system used mainly in defence applications which is used to locate the target, that is, to find its exact position in the range which it covers. The drawback of conventional pulse RADAR is that it can determine only the range, that is, the distance of the target from RADAR antenna. It cannot determine whether the target is moving or not and in which direction it is moving. Thus in order to determine the motion of the target we use MTI (Moving Target Indication) RADAR. MTI RADAR has become a boon for detecting motion of the targets in the field of RADAR Engineering. MTI RADAR is defined as the RADAR in which the Doppler effect can be employed to differentiate between stationary and moving targets, with the former suppressed and only the latter displayed. In this process, the permanent echoes as well as those from very slow moving objects (if desired) are not displayed on the PPI (plan position indicator), and the radar controller can pay attention to the real aircraft. Along with the detection of moving targets it also eliminates the effect of stationary objects or stationary clutters. This can be achieved by using the Delay line cancellor.

II. EVOLUTION OF RADAR

Previously, RADAR systems were very simple. There were no separate antennas for transmitter and receiver. A single antenna used to function as transmitter and receiver. A gaseous device was called as duplexer was used to separate the transmitter and receiver subsystems. For certain time the single

antenna used to work as a transmitter while for other time it used to function as a receiver. The transmitting and receiving functions were time multiplexed. The received echo was demodulated, amplified and compared with the threshold level. But the disadvantage was that the doppler frequency shift due to motion of the target was not detected. Thus such a RADAR could not detect moving target. It was used only to detect stationary targets.

After World War-I when aircrafts were used in war for the first time there was a need to detect moving targets in which the conventional RADAR failed. Also as the aviation industry progressed there was also a need to control the motion of aircrafts to prevent fatal accidents. Thus a special RADAR system to detect moving targets was developed called as MTI (Moving Target Indication) RADAR was developed. Another type of RADAR used to detect moving targets was Pulse Doppler RADAR. Both the RADAR systems used the concept of Doppler frequency shift or doppler effect to detect the moving targets. History was made when Croydon airport of London was the first airport to use ATC(Air Traffic Control) system in the year 1921. It used the RADARS used to detect moving targets.

III. DOPPLER FREQUENCY SHIFT

Doppler shift is an apparent change in frequency (or wavelength) due to the relative motion of two objects. Either one or both of the objects may be moving with respect to the ground. Radar systems exploit the Doppler shift to provide an indication of relative speed. When the two objects are approaching each other (closing), the Doppler shift causes a shortening of wavelength - or increase in frequency. When the two objects are receding from each other (opening), the Doppler shift causes a lengthening of wavelength - or decrease in frequency. In case of an MTI RADAR, when the target is moving towards the RADAR, the frequency of the echo received from the target increases whereas if the target is moving away from the RADAR, the frequency of the echo received from the target decreases. Difference in the transmitted frequency and received frequency from the target is called as doppler frequency and is denoted by f_d .

IV. DIFFERENCE BETWEEN PULSE DOPPLER RADAR AND MTI RADAR

Both this RADAR basically depends on same principle of Doppler frequency shift. But there are some difference that are some differences. MTI RADAR uses low pulse repetition frequency while pulse Doppler uses high and medium pulse repetition frequency. MTI RADAR has no range ambiguity while range ambiguity may occur in pulse Doppler.

Improvement factor need not to be improved in MTI RADAR while in pulse Doppler improvement in Improvement factor is needed. Usually magnetron oscillator is commonly used as transmitter, in pulse Doppler high power klystron amplifier is used as transmitter. MTI RADAR uses analog delay line canceller while in pulse Doppler it uses analog filter banks. MTI RADAR receives less clutter signal while pulse Doppler RADAR receives more clutter signals.

V. WORKING

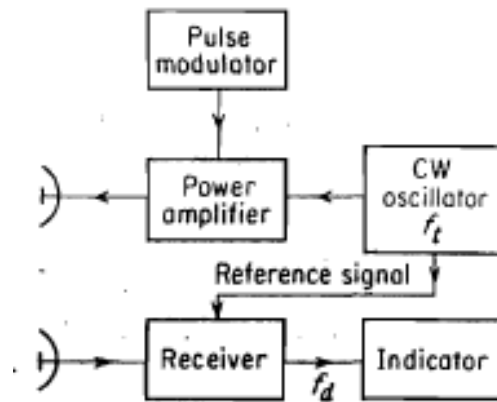

Fig.1 - Pulse Radar

A simple CW radar consists of a transmitter, receiver, indicator, and the necessary antennas. In principle, the CW radar may be converted into a pulse radar as shown in Fig. 1 by providing a power amplifier and a modulator to turn the amplifier on and off for the purpose of generating pulses. The chief difference between the pulse radar and the CW radar is that a small portion of the CW oscillator power that generates the transmitted pulses is diverted to the receiver to take the place of the local oscillator. It acts as the coherent reference needed to detect the doppler frequency shift.

If the CW oscillator voltage is represented as

$$V_{ref} = A_2 \sin 2\pi f_t t$$

and the doppler-shifted echo-signal voltage is

$$V_{echo} = A_3 \sin \left[2\pi(f_t \pm f_d)t - \frac{4\pi f_t R_0}{c} \right]$$

Where:

A_2 = amplitude of reference signal

A_3 = amplitude of signal received from a target at a range R_0 ,

f_d = doppler frequency shift

t = time

c = velocity of propagation

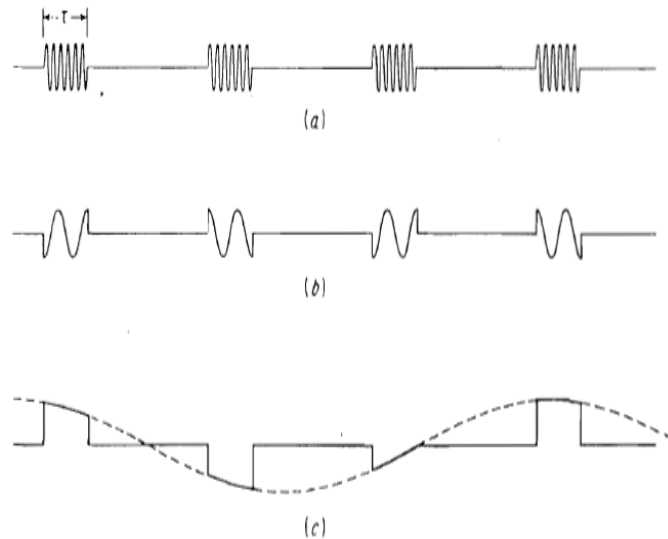

Fig.2 - A scope display

Moving targets may be distinguished from stationary targets by observing the video output on an A-scope (amplitude vs. range). A single sweep on an A-scope might appear as in Fig.2. This sweep slows several fixed targets and two moving targets indicated by the two arrows. On the basis of a single sweep, moving targets cannot be distinguished from fixed targets. (It may be possible to distinguish extended ground targets from point targets by the string of the echo pulses. However, this is not a reliable means of discriminating moving from fixed targets since some fixed targets can look like point targets, e.g., a water tower. Also, some moving targets such as aircraft flying in formation can look like extended targets.) Successive A-scope sweeps (pulse-repetition intervals) are shown in Fig.. Echoes from fixed targets remain constant throughout, but echoes from moving targets vary in amplitude from sweep to sweep at a rate corresponding to the doppler frequency.

A) MTI operation

The block diagram of a more common MTI radar employing a power amplifier is shown. The significant difference between this MTI configuration and that Figure is the manner in which the reference signal is generated. In Fig.3, the coherent reference is supplied by an oscillator called the coho, which stands for coherent oscillator. The coho is a stable oscillator whose frequency is the same as the intermediate frequency used in the receiver. In addition to providing the reference signal the output of the coho. is also mixed with the local-oscillator frequency. The local oscillator- must be a stable oscillator and is called *stalo.*. The RF echo signal is heterodyned with the stalo signal to produce the IF frequency just as in the superheterodyne receiver. They serve in both the receiver and the transmitter mode. The characteristic feature of coherent MTI radar is that the transmitted signal must be coherent (in phase) with the reference signal in the receiver. This is accomplished in the radar

system diagramed in Fig.3 by generating the transmitted signal from a reference signal. The function of the stalo is to provide the necessary frequency translation from the IF to the transmitted frequency. Although the phase of the stalo influences the phase of the transmitted signal, any stalo phase shift is canceled on reception because the stalo that generates the transmitted signal also acts as the local oscillator in the receiver. The reference signal from the coho and the IF echo signal are both fed into a mixer called the *phase detector*.

The phase detector differs from the normal amplitude detector since its output is proportional to the phase difference between the two input signals.

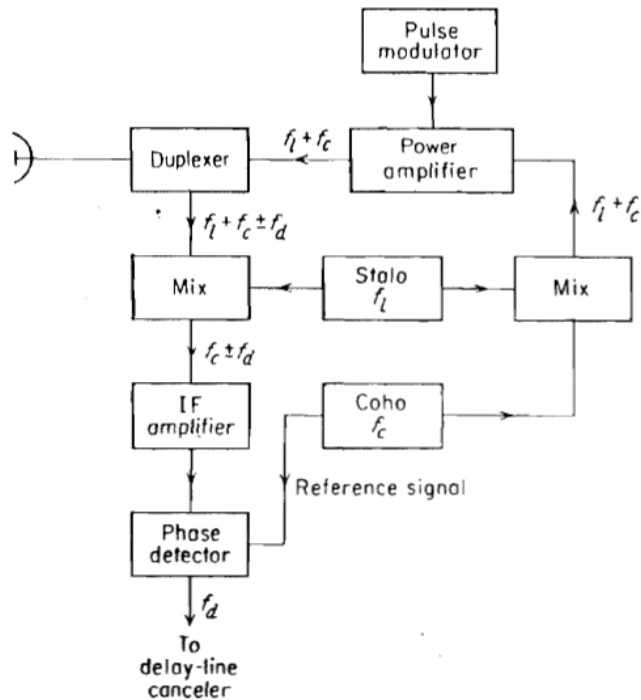

Fig.3-MTI block diagram

B) Delay Line Cancellor

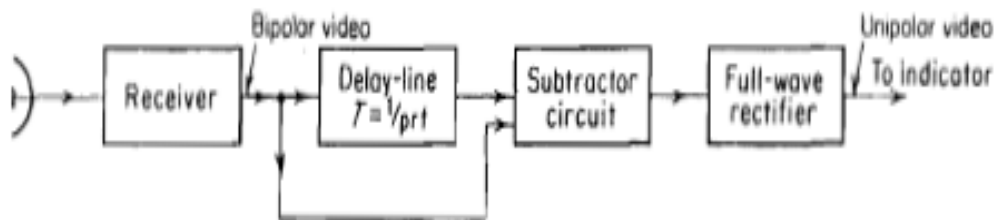

Fig.4 – Delay Line Cancellor

The simple MTI delay-line canceller shown in Fig.4 is an example of a time-domain filter. The capability of this device depends on the quality of the medium used as the delay line. The Pulse modulator delay line must introduce a time delay equal to the pulse repetition interval. For typical ground-based air-surveillance radars this might be several milliseconds. Delay times of this magnitude cannot be achieved with practical electromagnetic transmission lines. By converting the electromagnetic signal to an 'acoustic signal it is possible to utilize delay lines of a reasonable physical length since the velocity of propagation of acoustic waves is about that of electromagnetic waves. After the necessary delay is introduced by the acoustic line, the signal is converted back to an electromagnetic signal for further processing. The early acoustic delay lines developed during World War II used liquid delay lines filled with either water or mercury. Liquid delay lines were large and inconvenient to use. They were replaced in the mid-1950s by the solid fused-quartz delay line that used multiple internal reflections to obtain a compact device. These analog acoustic delay lines were, in turn supplanted in the early 1970s by storage devices based on digital computer technology. The use of digital delay lines requires that the output of the MTI receiver phase-detector be quantized into a sequence of digital words. The compactness and convenience of digital processing allows the implementation of more complex delay-line cancellers with filter characteristics not practical with analog methods. One of the advantages of a time-domain delay-line canceller as compared to the more conventional frequency-domain filter is that a single network operates at all ranges and does not require a separate filter for each range resolution cell. Frequency-domain doppler filterbanks are of interest in some forms of MTI and pulse-doppler radar.

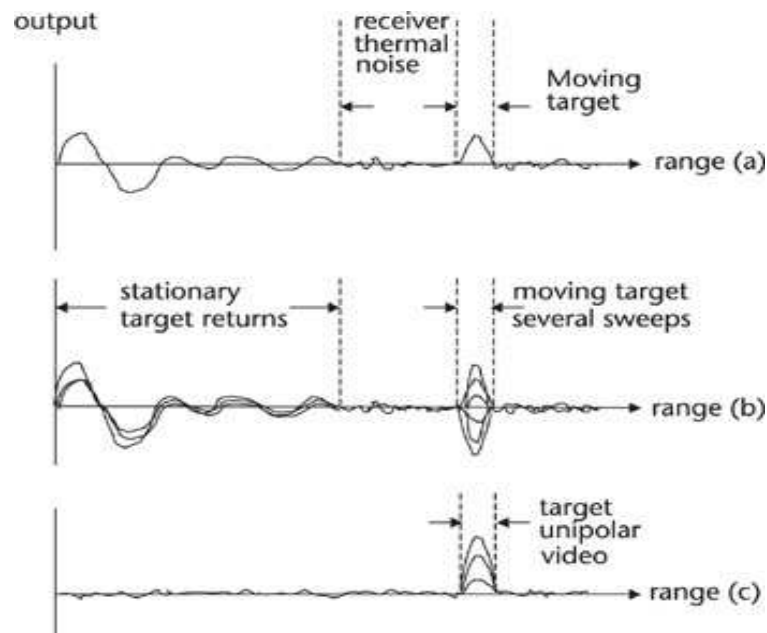

Fig.5 – Delay Line Canceller Working

C) Filter characteristics of the delay-line canceler

The delay-line canceler acts as a filter which rejects the d-c component of clutter. Because of its periodic nature, the filter also rejects energy in the vicinity of the pulse repetition frequency and its harmonics. The video signal received from a particular target at a range R , is

$$V1 = k \sin (2\Pi fdt - \Phi), \dots \dots \dots \text{Eqn 1}$$

where Φ = phase shift and k = amplitude of video signal. The signal from the previous transmission, which is delayed by a time T = pulse repetition interval, is

$$V2 = k \sin [2\Pi fd (t - T) - \Phi] \dots \dots \dots \text{Eqn 2.}$$

Everything else is assumed to remain essentially constant over the interval T so that k is the same for both pulses. The output from the subtractor is

$$V = V1 - V2 = 2k \sin \Pi fd T \cos [2\Pi fd(t - T/2) - \Phi] \dots \dots \text{Eqn 3}$$

It is assumed that the gain through the delay-line canceler is unity. The output from the canceler consists of a cosine wave at the doppler frequency & with an amplitude $2k \sin \Pi fd T$: Thus the amplitude of the canceled video output is a function of the doppler frequency shift and the pulse-repetition interval, or prf. The magnitude of the relative frequency-response of the delay-line canceler [ratio of the amplitude of the output from the delay-line canceler, $2k \sin (\Pi fd T)$, to the amplitude of the normal radar video k] is shown in Fig.6.

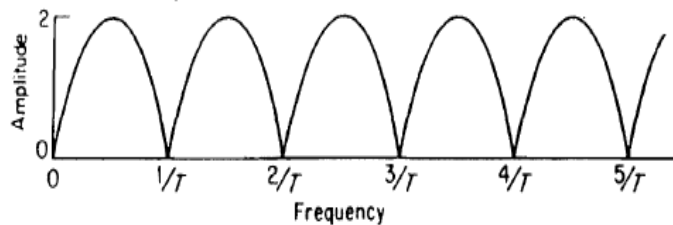

Fig.6 - Delay Line Frequency Response

VI. DIGITAL SIGNAL PROCESSING

The introduction of practical and economical digital processing to MTI radar allowed a significant increase in the options open to the signal processing designer. The convenience of digital processing meant that multiple delay-line cancelers with tailored frequency-response can be obtained.

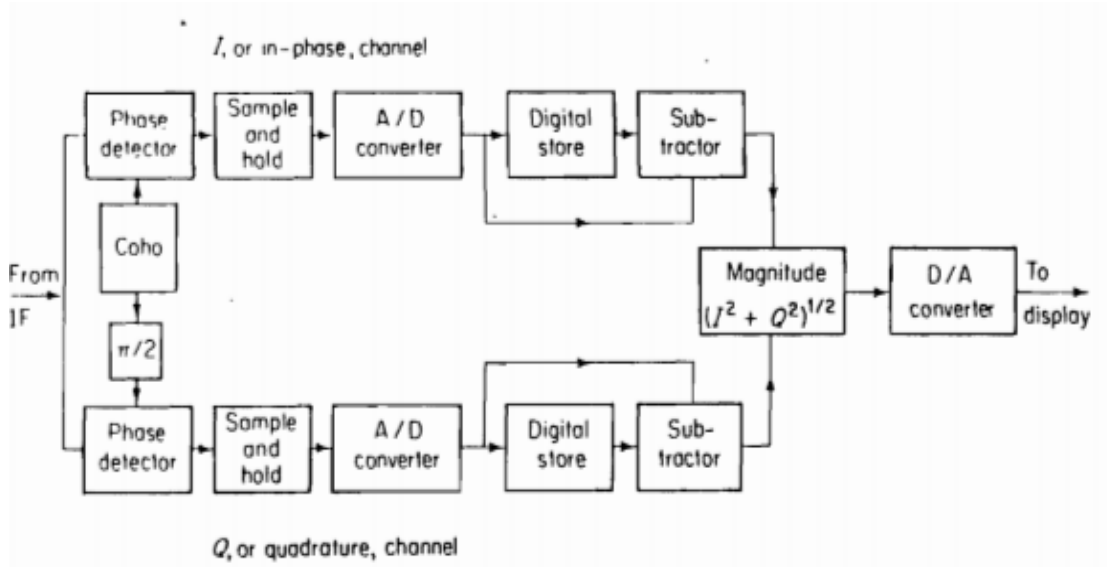

Fig.7 – Digital MTI Signal Processor

A simple block diagram of a digital MTI processor is shown in Fig. 7. From the output of the IF amplifier the signal is split into two channels. One is denoted I, for in-phase channel. The other is denoted Q, for quadrature channel, since a 90° phase change ($\pi/2$ radians) is introduced into the coho reference signal at the phase detector. The purpose of the quadrature channel is to eliminate the blind speeds.

VII. BLIND SPEED LIMITATION

The response of the single-delay-line canceller will be zero whenever the argument $\pi f_d T$ in the amplitude factor of is $0, \pi, 2\pi, \dots$, etc., or when

$$f_d = \frac{n}{T} = n f_p$$

where $n = 0, 1, 2, \dots$, and f_p = pulse repetition frequency. The delay-line canceller not only eliminates the d-c component caused by clutter ($n = 0$), but unfortunately it also rejects any moving target whose doppler frequency happens to be the same as the prf or a multiple thereof. Those relative target velocities which result in zero MTI response are called **blind speeds** are given by

$$v = n\lambda/2T = n\lambda f_p/2$$

$$n = 1, 2, 3, \dots$$

where v_n , is the nth blind speed.

The blind speeds are one of the limitations of pulse MTI radar which do not occur with CW radar. They are present in pulse radar because doppler is measured by discrete samples -(pulses) at the prf rather than continuously. If the first blind speed is to be greater than the maximum radial velocity

expected from the target, the product λR must be large. Thus the MTI radar must operate at long wavelengths (low frequencies) or with high pulse repetition frequencies, or both. Unfortunately, there are usually constraints other than blind speeds which determine the wavelength and the pulse repetition frequency. Therefore blind speeds might not be easy to avoid. Low radar frequencies have the disadvantage that antenna beamwidths, for a given-size antenna, are wider than at the higher frequencies and would not be satisfactory in applications where angular accuracy or angular resolution is important. The pulse repetition frequency cannot always be varied over wide limits since it is primarily determined by the unambiguous range requirement.

A) Staggered Pulse Repetitive Frequency

The use of more than one pulse repetition frequency offers additional flexibility in the design of MTI doppler filters. It not only reduces the effect of the blind speeds, but it also allows a sharper low-frequency cutoff in the frequency response than might be obtained with a cascade of single-delay-line cancelers with sinc^2 response.

The blind speeds of two independent radars operating at the same frequency will be different if their pulse repetition frequencies are different. Therefore, if one radar were "blind" to moving targets, it would be unlikely that the other radar would be "blind" also. Instead of using two separate radars, the same result can be obtained with one radar which time-shares its pulse repetition frequency between two or more different values (multiple prfs). The pulse repetition frequency might be switched every other scan or every time the antenna is scanned a half beam width, or the period might be alternated on every other pulse. When the switching is pulse to pulse, it is known as a staggered prf. An example of the composite (average) response of an MTI radar operating with two separate pulse repetition frequencies on a time-shared basis is shown in Fig. 7. repetition frequencies are in the ratio of 5 : 4. Note that the first blind speed of the composite response is increased several times over what it would be for a radar operating on only a single pulse repetition frequency. Zero response occurs only when the blind speeds of each prf coincide.

VIII . OTHER LIMITATIONS TO MTI PERFORMANCE

There are limitations to the performance of MTI radar. The degradation in the performance of MTI radar are caused due to following reasons:

A) *Antenna scanning modulation*

The duration of echo signal received from a target or a clutter scatterer as antenna of pulse radar scans is given by $t_0 = N_b / f_p = \Theta_b / \Theta_s$ where

N_b =number of pulses received

f_p =pulse repetition frequency

Θ_b =antenna beamwidth in degrees

Θ_s =antenna scanning rate in degree/second

The bandwidth of the frequency spectrum is inversally proportional to the time duration to. Consequently,even if the clutter scatterer were perfectly stationary and there were no instabilities in equipment ,there would be still finite spectral spread due to finite duration of echo signal.

This limitation has been called antenna scanning modulation ,but it is basically due to finite time on target.The longer time on the target,less will be the spread in the clutter spectrum.

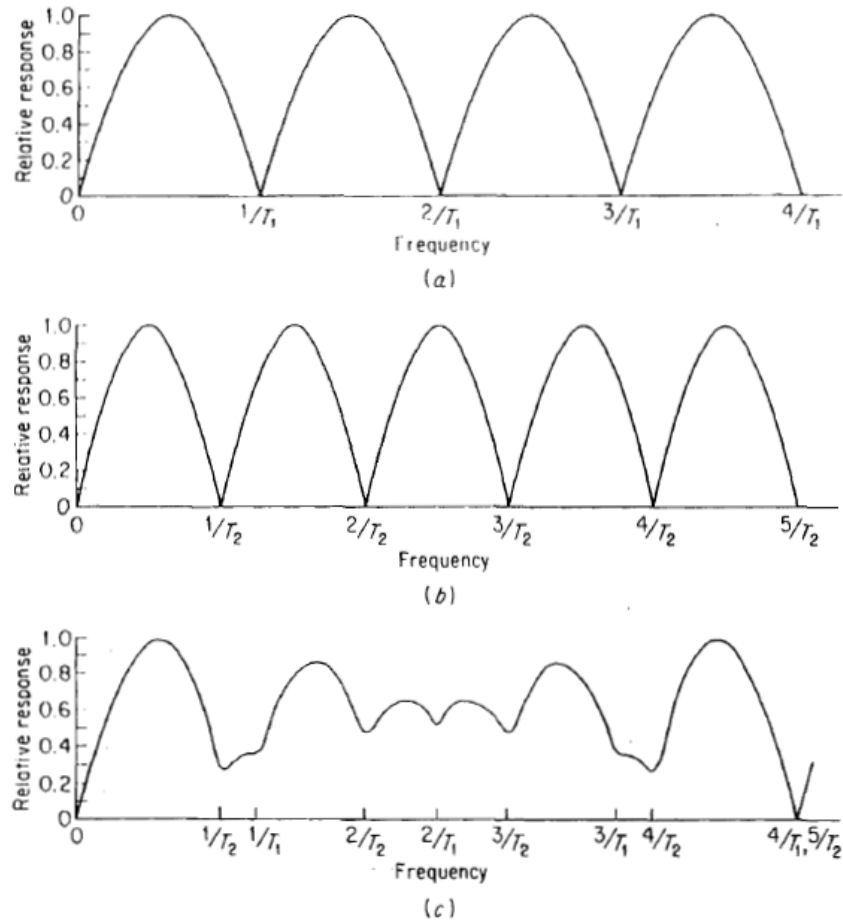

Fig.7 – Staggered PRF

B.)Internal fluctuations of clutter

Echoes from mountains, rocks, buildings, water towers ,fences, thick tree trunks, hills usually stationary in nature.

Many other sources of clutter echoes however can be in motion .These include echoes from sea, rain, chaff, rees, large vegetations, structures blowing in wind etc. The amplitude and phase fluctuations of windblown structures results in widened frequency spectrum of clutter echo that can be a limitation on performance of MTI radar.

C) .Equipment instabilities

Changes in amplitude, frequency or phase of stalo and coho oscillators as well as changes in pulse to pulse characteristics of transmitted signal or errors in timing can result in uncanceled clutter echoes and causes limit to improvement factor of MTI radar that can be achieved.

D). Limiting

A limiter in the MTI receiver has sometimes been used to reduce the clutter to the level of receiver noise. The hard limiters used in MTI radar cause quite serious degradation of the MTI performance. Instead a limiter should be set above the receiver noise by an amount equal to MTI radar improvement factor.

IX. APPLICATIONS

A) Astronomy

Redshift of spectral lines in the optical spectrum of a supercluster of distant galaxies (right), as compared to that of the Sun (left). The Doppler effect for electromagnetic waves such as light is of great use in astronomy and results in either a so-called redshift or blueshift. It has been used to measure the speed at which stars and galaxies are approaching or receding from us, that is, the radial velocity. This is used to detect if an apparently single star is, in reality, a close binary and even to measure the rotational speed of stars and galaxies.

The use of the Doppler effect for light in astronomy depends on our knowledge that the spectra of stars are not continuous. They exhibit absorption lines at well defined frequencies that are correlated with the energies required to excite electrons in various elements from one level to another. The Doppler effect is recognizable in the fact that the absorption lines are not always at the frequencies that are obtained from the spectrum of a stationary light source. Since blue light has a higher frequency than red light, the spectral lines of an approaching astronomical light source exhibit a blueshift and those of a receding astronomical light source exhibit a redshift.

Among the nearby stars, the largest radial velocities with respect to the Sun are +308 km/s (BD-15°4041, also known as LHS 52, 81.7 light-years away) and -260 km/s (Woolley 9722, also known as Wolf 1106 and LHS 64, 78.2 light-years away). Positive radial velocity means the star is receding from the Sun,

The Doppler effect is used in some types of radar, to measure the velocity of detected objects. A radar beam is fired at a moving target — e.g. a motor car, as police use radar to detect speeding motorists — as it approaches or recedes from the radar source. Each successive radar wave has to travel farther to reach the car, before being reflected and re-detected near the source. As each wave has to move farther, the gap between each wave increases, increasing the wavelength. In some situations, the radar

beam is fired at the moving car as it approaches, in which case each successive wave travels a lesser distance, decreasing the wavelength. In either situation, calculations from the Doppler effect accurately determine the car's velocity. Moreover, the proximity fuze, developed during World War II, relies upon Doppler radar to detonate explosives at the correct time, height, distance, etc.

B) RADAR Gun

Police use a radar detector to determine the speed of a car as it moves down the highway. Radar waves are transmitted from the police car at a certain frequency. Recall that waves have both amplitude and frequency. When the waves bounce off a moving object their frequency is effected. As the radio waves bounce of a car that is moving toward the detector the frequency of the wave decreases. If the waves bounce of a car moving away from the detector the frequency of the wave increases. The detector uses the difference in the transmitted and received wave frequencies to determine the speed of the car.

C) Military purpose

In aviation, aircraft are equipped with radar devices that warn of obstacles in or approaching their path and give accurate altitude readings. The first commercial device fitted to aircraft was a 1938 Bell Lab unit on some United Air Lines aircraft. Such aircraft can land in fog at airports equipped with radar-assisted ground-controlled approach systems in which the plane's flight is observed on radar screens while operators radio landing directions to the pilot.

X. CONCLUSION

Here we have presented a special application of radar ie. MTI radar which is far more superior to ordinary radar. The basic principle involved and its operation has been elaborated along with its limitations. MTI radar can be used for various air borne as well as ground based applications and shows a lot of promise in the near future.

REFERENCES

1. Introduction to RADAR system by Merrill I.Skolnik
2. RADAR Systems by V.S. Bagad
3. Wikipedia.com
4. Britinca.com
5. Modern RADAR systems by Hamish Meikle